

Wall Mount Single Section Cabinet

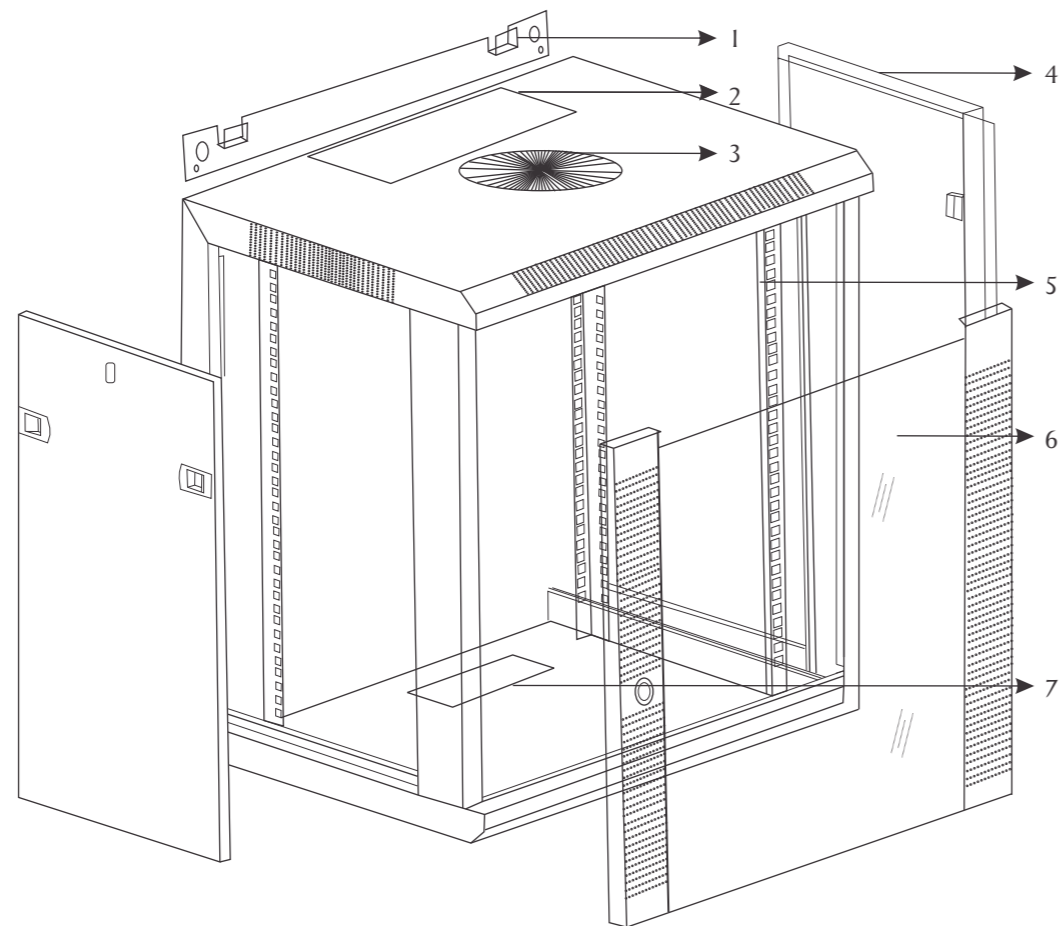

- 1. Wall mount Panel
- 2. Top Cable Entry
- 3. Soundless Top Fan
- 4. Removable Side Panels
- 5. Mounting Profile
- 6. Front Glass Door with Lock
- 7. Bottom Cable Entry

Wall Mount Double Section Cabinet

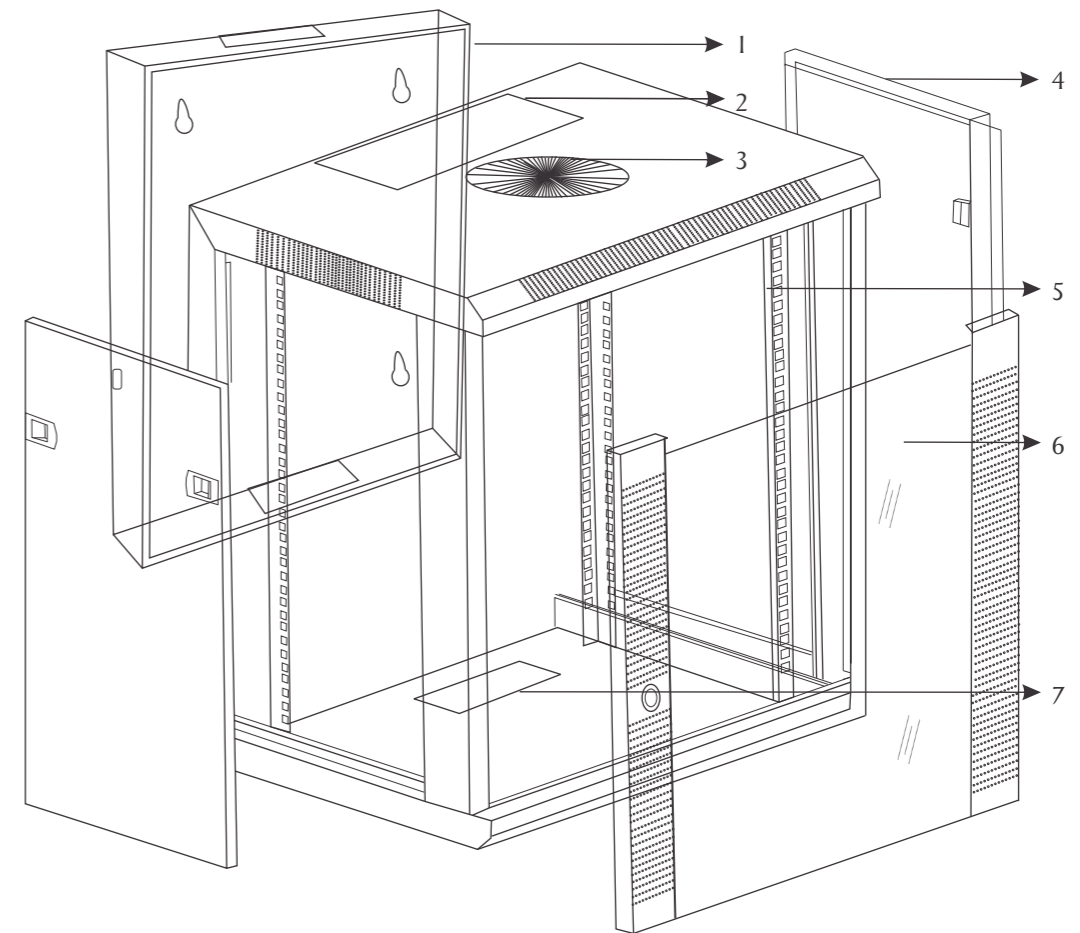

- 1. Rear Section with cable entry
- 2. Top Cable Entry
- 3. Soundless Top Fan
- 4. Removable Side Panels
- 5. Mounting Profile
- 6. Front Glass Door with Lock
- 7. Bottom Cable Entry

RACKS

RACKS

Wall Mount Single Section Cabinets



Description

AVAYO wall mount cabinets designed to accommodate multiple 19" equipment modules for data communication and telecommunication network solutions. Size ranges from 4U till 18U, these cabinets available in various dimensions to suit the requirements of customers.

Applications and Standards

- Housing CCTV, Servers, UPS systems, Network and MATV equipment
- Comply with ANSI/EIA-RS-310-D, IEC 297-2, DIN 41491
- Available in 4U, 6U, 9U, 12U, 15U and 18U

Physical Characters

Series	: Economy Series
Type	: Single section, wall mount
Protection Rating	: IP 20
Material	: SPCC quality cold rolled steel
Surface Finish	: Degrease acid pickling, rust prevention and Parkerizing, Pure water cleaning, static electricity painting over Powder coating durable.
Color	: Black (RAL 9005) or Grey (RAL 7035)
Width	: 600mm
Depth	: 450, 550 and 600 mm
Height	: Varies as per the number of Us
Frame Type	: Welded rigid frame
Construction	: 1.2 to 1.5 mm gauge steel thickness
Profile	: 19" adjustable profile in the front and rear.
Profile Standard	: 2.0 mm gauge heavy duty Universal/EIA type.
Loading Rate	: Up to 30 Kgs
Front Door	: 180 degree opening type tempered Glass door/ metal door With round lock

Side Panels : Clutch opening type side panels with optional lock system
Cooling Fan : 1 unit roof mount type, heavy duty, noiseless.

Cable Access : Top and Bottom cable entry
Mounting Accessories : Heavy duty cage nuts Universal/ TIA/EIA standard

Ordering Information

Part No.	Dimension	Accessories
AVE-W04S-6045B/G	4U SS 600X450X250	BLACK/ GREY
AVE-W04S-6055B/G	4U SS 600X550X250	BLACK/ GREY
AVE-W06S-6045B/G	6U SS 600X450X320	BLACK/ GREY
AVE-W06S-6055B/G	6U SS 600X550X320	BLACK/ GREY
AVE-W06S-6060B/G	6U SS 600X600X320	BLACK/ GREY
AVE-W09S-6045B/G	9U SS 600X450X500	BLACK/ GREY
AVE-W09S-6055B/G	9U SS 600X550X500	BLACK/ GREY
AVE-W09S-6060B/G	9U SS 600X600X500	BLACK/ GREY
AVE-W12S-6045B/G	12U SS 600X450X650	BLACK/ GREY
AVE-W12S-6055B/G	12U SS 600X550X650	BLACK/ GREY
AVE-W12S-6060B/G	12U SS 600X600X650	BLACK/ GREY
AVE-W15S-6045B/G	15U SS 600X450X750	BLACK/ GREY
AVE-W15S-6055B/G	15U SS 600X550X750	BLACK/ GREY
AVE-W15S-6060B/G	15U SS 600X600X750	BLACK/ GREY
AVE-W18S-6045B/G	18U SS 600X450X900	BLACK/ GREY
AVE-W18S-6055B/G	18U SS 600X550X900	BLACK/ GREY
AVE-W18S-6060B/G	18U SS 600X600X900	BLACK/ GREY

Wall Mount Double Section Network Cabinets



Description

Double section cabinets are designed for easy access of the rear side of a wall mount cabinet. The rear section of the cabinet mount to the wall and the front section hinged to the rear section with locks.

Applications and Standards

- Housing CCTV, Servers, UPS systems, Network and MATV equipment
- Comply with ANSI/EIA-RS-310-D, IEC 297-2, DIN 41491
- Available in 4U, 6U, 9U, 12U, 15U and 18U

Physical Characters

Series	: Economy Series
Type	: Double section, wall mount
Protection Rating	: IP 20
Material	: SPCC quality cold rolled steel
Surface Finish	: Degrease acid pickling, rest prevention and Parkerizing, Pure water cleaning, static electricity painting over Powder coating durable.
Color	: Black (RAL 9005) or Grey (RAL 7035)
Width	: 600 mm
Depth	: 560 and 600 mm
Height	: Varies as per the number of Us
Frame Type	: Welded rigid frame
Construction	: 1.2 to 2.0 mm gauge steel thi
Profile	: 19" adjustable profile in the frontand rear
Profile Standard	: 2.0 mm gauge heavy duty Universal/EIA type.
Loading Rate	: Up to 30 kgs
Front Door	: 180 degree opening type tempered Glass door/ Metal door with round lock

Side Panels	:	Clutch opening type side panels with optional lock system.
Mounting Type	:	Rear section mount to the wall and front section hinged to the rear section with safety lock.
Cooling Fan	:	1 unit roof mount type, heavy duty, noiseless.
Cable Access	:	Top and Bottom cable entry.
Mounting Accessories	:	Heavy duty cage nuts Universal/ TIA/EIA standard.

Ordering Information

Part No.	Dimension	Color
AVE-W04D-6056B/G	4U DS 600X560X250	Black/Grey
AVE-W06D-6056B/G	6U DS 600X560X320	Black/Grey
AVE-W09D-6056B/G	9U DS 600X560X500	Black/Grey
AVE-W12D-6056B/G	12U DS 600X560X650	Black/Grey
AVE-W15D-6056B/G	15U DS 600X560X750	Black/Grey
AVE-W18D-6056B/G	18U DS 600X560X900	Black/Grey
AVE-W18D-6060B/G	18U DS 600X600X900	Black/Grey

B-Black
G- Grey