



EvoLine

**“Evolved Engineering
for Fast & Long Lasting
Networking Installations.”**

- Powerful
- Flexible
- Time & Cost-Effective

**19” Free-Standing Network Cabinet Series for
Fast & Easy Network Installations, ideal for
Infrastructural Cabling, Data Distribution, Basic
Server Housing, Massive Cabling.**

SIZE RANGE

26U to 47U Height,
600, 780 mm Width
600 to 1200mm Depth

HIGHLIGHTS

POWERFUL

- 1000 KG Load Carrying Capacity:
 - 24-times folded Frame
 - Reinforced, Modular Chassis Design
 - Adjustable Mounting Rails, Tightly fixed on Top and Bottom Chassis
- Resistance against tough conditions:
 - Impact and Scratch resistant easy cleaning painting texture



FLEXIBLE

- The iconic Pagoda style Vented Top Cover as an option
- Standard Rear-Panel can be replaced with other Door Options
- Levelling Feet as Standard, Optional Casters
- Optional Floor fixing, Plinth & Baying Kits
- Reliable Fan tray options:
 - Equipped with up to 6 x Fans, On/Off button, fuse, analogue or digital thermostat & wired mesh fences.

TIME & COST-EFFECTIVE

- Also available as Easy Assembly Flat-pack with just 1 type of screw
- 4-Way Easy Access:
- Lockable-Removable Doors, Rear & Side Panels
- 120 Degree Door Opening
- Adjustable Mounting Rails
- Multiple brushed Cable Entries on Top and Bottom

EvoLine Free Standing

EvoLine Cabinets Size Range

Part Number	Product definition (mm)	U size	Width: overall (mm)	Depth: overall (mm)	Depth: max mounting profile (mm)	Height: vertical mounting profile (mm)	Height: without levelling feet (mm)	Height: with levelling feet min (mm)	Height: with casters (mm)
EVL70116U6060	16U 600x600	16	600	600	460	750	816	841	896
EVL70116U6080	16U 600x800	16	600	800	660	750	816	841	896
EVL70120U6060	20U 600x600	20	600	600	460	919	994	1019	1074
EVL70120U6080	20U 600x800	20	600	800	660	919	994	1019	1074
EVL70122U6060	22U 600x600	22	600	600	460	1008	1083	1108	1163
EVL70122U6080	22U 600x800	22	600	800	660	1008	1083	1108	1163
EVL70126U6010	26U 600x1000	26	600	1000	860	1185	1260	1285	1340
EVL70126U6060	26U 600x600	26	600	600	460	1185	1260	1285	1340
EVL70126U6080	26U 600x800	26	600	800	660	1185	1260	1285	1340
EVL70132U6060	32U 600x600	32	600	600	460	1452	1527	1552	1607
EVL70132U6080	32U 600x800	32	600	800	660	1452	1527	1552	1607
EVL70132U8060	32U 780x600	32	780	600	460	1452	1527	1552	1607
EVL70132U8080	32U 780x800	32	780	800	660	1452	1527	1552	1607
EVL70136U6010	36U 600x1000	36	600	1000	860	1630	1705	1730	1785
EVL70136U6060	36U 600x600	36	600	600	460	1630	1705	1730	1785
EVL70136U6080	36U 600x800	36	600	800	660	1630	1705	1730	1785
EVL70136U8060	36U 780x600	36	780	600	460	1630	1705	1730	1785
EVL70136U8080	36U 780x800	36	780	800	660	1630	1705	1730	1785
EVL70139U6060	39U 600x600	39	600	600	460	1763	1838	1863	1918
EVL70139U6080	39U 600x800	39	600	800	660	1763	1838	1863	1918
EVL70139U8060	39U 780x600	39	780	600	460	1763	1838	1863	1918
EVL70139U8080	39U 780x800	39	780	800	660	1763	1838	1863	1918
EVL70142U6010	42U 600x1000	42	600	1000	860	1897	1972	1997	2052
EVL70142U6060	42U 600x600	42	600	600	460	1897	1972	1997	2052
EVL70142U6080	42U 600x800	42	600	800	660	1897	1972	1997	2052
EVL70142U8010	42U 780x1000	42	780	1000	860	1897	1972	1997	2052
EVL70142U8060	42U 780x600	42	780	600	460	1897	1972	1997	2052
EVL70142U8080	42U 780x800	42	780	800	660	1897	1972	1997	2052
EVL70144U6060	44U 600x600	44	600	600	460	1986	2060	2085	2140
EVL70144U6080	44U 600x800	44	600	800	660	1986	2060	2085	2140
EVL70144U8060	44U 780x600	44	780	600	460	1986	2060	2085	2140
EVL70144U8080	44U 780x800	44	780	800	660	1986	2060	2085	2140
EVL70147U6010	47U 600x1000	47	600	1000	860	2119	2194	2219	2274
EVL70147U6060	47U 600x600	47	600	600	460	2119	2194	2219	2274
EVL70147U6080	47U 600x800	47	600	800	660	2119	2194	2219	2274
EVL70147U8010	47U 780x1000	47	780	1000	860	2119	2194	2219	2274
EVL70147U8060	47U 780x600	47	780	600	460	2119	2194	2219	2274
EVL70147U8080	47U 780x800	47	780	800	660	2119	2194	2219	2274

EvoLine Free Standing

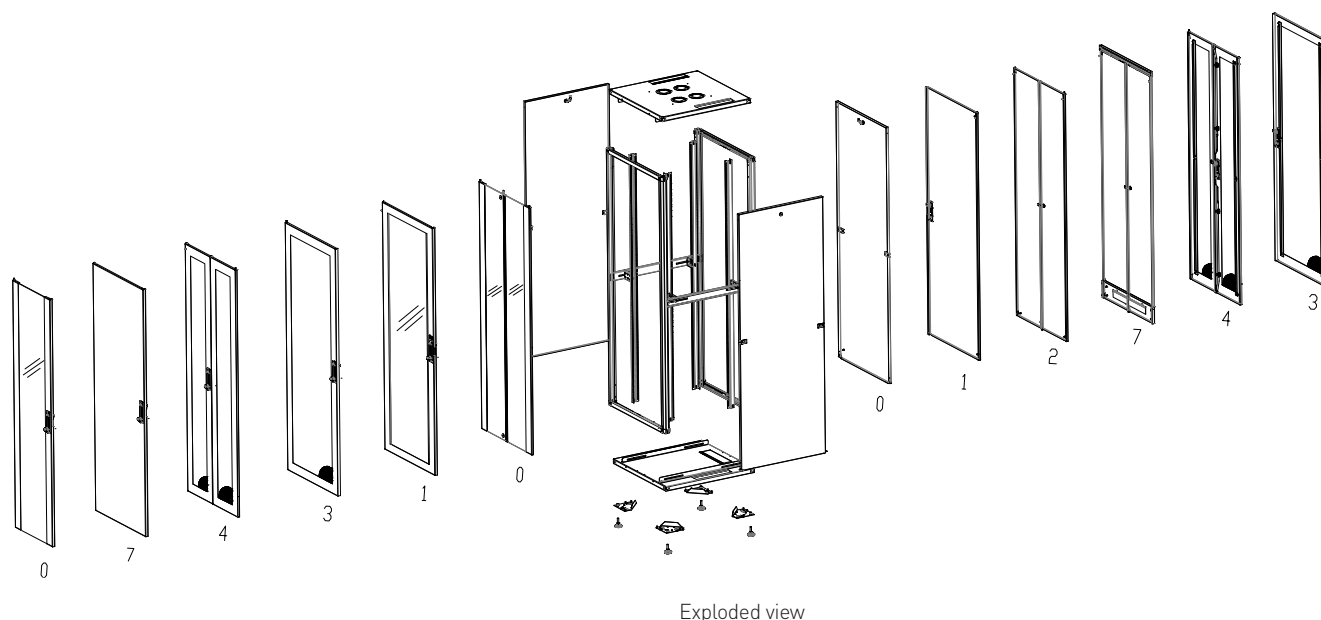

EvoLine Door Matrix

Door Code	Description	EVL W:600	EVL W:800
FRONT			
0	Single Glass Front Door, single point locking	Standard	
0	Double Glass Front Door, two point barrel locking		Standard
1	Single, Full Frame Glass Front Door, single point locking	Optional	Optional
3	Single Vented Front Door, 63% perforated, single point locking	Optional	Optional
4	Double Vented Front Door, 63% perforated, three point locking	Optional	Optional
7	Solid Metal Front Door	Optional	Optional
REAR			
0	Solid Metal Back Panel	Standard	Standard
1	Single Solid Metal Rear Door	Optional	Optional
2	Double Solid Metal Rear Door		Optional
3	Single Vented Rear Door, 63% perforated, single point locking	Optional	Optional
4	Double Vented Rear Door, 63% perforated, three point locking		Optional
7	Solid Metal Rear Door(s) with cable entries on bottom	Optional	Optional

Marked are also Default Config.

Example : EVL70142U8080L34M50

Product code	L	Front door	Rear door	Color
↓		↓	↓	↓
EVL70142U8080		Check the options From door matrix please (0-9)	Check the options From door matrix please (0-9)	M50 for Black M2 for Gray

EvoLine Special Accessories

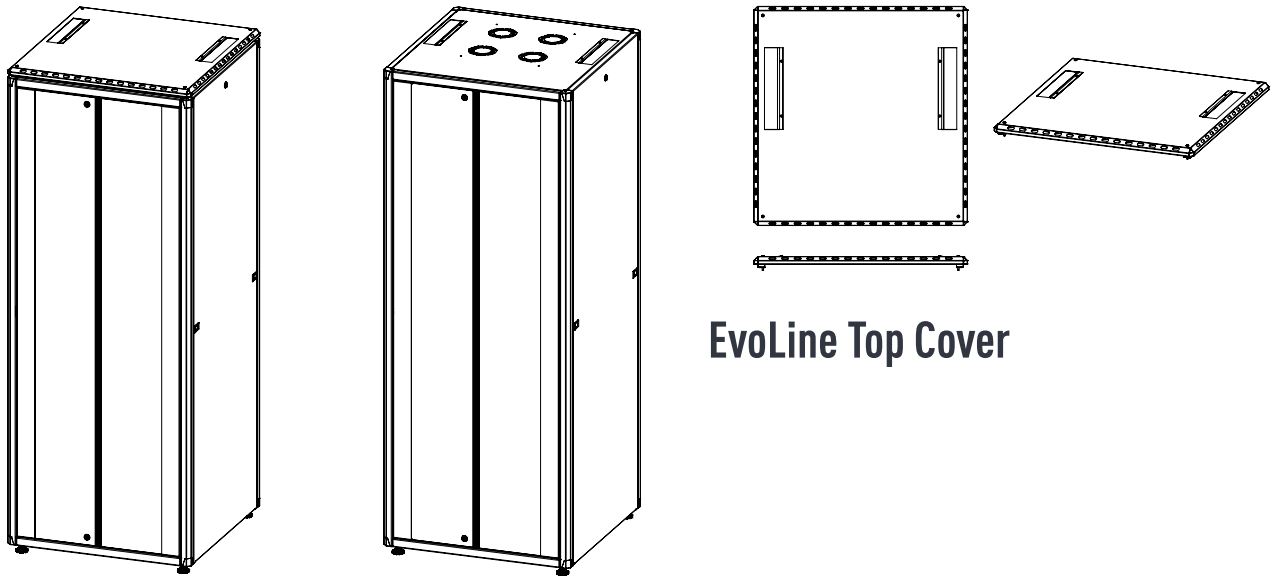

Special Accessories for EvoLine

	Part Number	Product definition
Cable Management	M44ORG16_03	16U vertical cable management panel
	M44ORG20_03	20U vertical cable management panel
	M44ORG22_03	22U vertical cable management panel
	M44ORG26_03	26U vertical cable management panel
	M44ORG32_03	32U vertical cable management panel
	M44ORG36_03	36U vertical cable management panel
	M44ORG39_03	39U vertical cable management panel
	M44ORG42_03	42U vertical cable management panel
	M44ORG44_03	44U vertical cable management panel
	M44ORG47_03	47U vertical cable management panel
Top Cover	EVL794M81L00	Top cover width=800 mm /depth=1000 mm
	EVL794M88L00	Top cover width=800 mm /depth=800 mm
	EVL794M66L00	Top cover width=600 mm /depth=600 mm
	EVL794M68L00	Top cover width=600 mm /depth=800 mm
	EVL794M86L00	Top cover width=800 mm /depth=600 mm
	EVL794M61L00	Top cover width=600 mm /depth=1000 mm
Cooling	EVL796M02L00	Cooling unit (2 fan + thermostat)
	EVL796M04L00	Cooling unit (4 fan + thermostat)
Plinths	EVL795M66L00	Plinth width=600 mm /depth=600 mm
	EVL795M68L00	Plinth width=600 mm /depth=800 mm
	EVL795M61L00	Plinth width=600 mm /depth=1000 mm
	EVL795M86L00	Plinth width=800 mm /depth=600 mm
	EVL795M88L00	Plinth width=800 mm /depth=800 mm
	EVL795M81L00	Plinth width=800 mm /depth=1000 mm
19"	100	19" Mounting angles

TESTS AND CERTIFICATIONS

IP protection degree

IP20 accordingly EN61587-1, IEC 60529

PURCHASED PRODUCT CERTIFICATIONS

Sheet steel

DIN EN 10130 - 99 Ereğli DC-01 6112, 7122, RoHS

Electrostatic powder coating

ISO 9001, ISO 2178, ISO 2813, ISO 6272, ISO 8130-5,
ISO 8130-3, RoHS

Fan

ISO 9001, CE {89/336/EEC EMC, 73/23/EEC LVD}, RoHS

Glass

ISO 9001, EN 12150 - 1: 2000 tempered and secure

Fixings

DIN 7985, DIN 965, DIN 7981, DIN 934, DIN 985, DIN 933,
RoHS

Casters

TS EN 12530, TS EN 12532, RoHS

Lock

DIN 1743, DIN 53571, RoHS

Shipping structure

Assembled / Flat Pack

Mounting type

Stand alone

Load carrying capacity (kg)

1000 kg

Certification on product

TSE, EAC

Surface finish

Electrostatic powder coated c/with surface treatment
60-120 micron paint thickness and tested according to
IEC 60068-2-1,2-2, 2-30,2-42, 2-43, 2-49, 2-11

Standard colour

Black: RAL 9005, Gray: RAL 7035

IP protection standard

IP20

FRONT DOOR

Shatterproof glass with left and right metal frame

Glass

4 mm thickness full-length smoked, shatterproof,
tempered, secure

Front door construction

W = 600 single opening W= 800 double opening

Front door lock

2 point locking barrel type

Adhesive material

High density polyurethane DIN 53479, DIN 53505

SIDE PANEL

Solid metal, 1 mm left and right (2 ea.)

Side panel construction

Lockable, removable c/with slam latches and lock

Side panel lock

Barrel type lock unit, single point + Slam latch (2 ea)

REAR DOOR

Solid metal, 1 mm

Rear door construction

W = 600 Single door opening, lockable, removable

W = 800 Double door opening, lockable, removable

Rear door lock

Single Barrel type lock unit, single point

FRAMEWORK

Top and bottom base units

Solid metal, 1,5 mm

Top and bottom base units construction

Completely modular

Uprights

Solid metal, 1,5 mm

Uprights construction

Tightly fixed into top and bottom base units 6 times
folded

INTERIOR PARTS

19" mounting angles

Solid metal, 1,5 mm, 3 times folded

"U" marking available,

2 ea. at rear, 2 ea. at front

19" C type support rails in depth

Solid metal, 1,5 mm

L Type Top and bottom Rail supports;

1,5 to 2.5mm 4 folded galvanized steel.



PLEASE CONTACT US FOR FURTHER OPTIONS & REQUIREMENTS